

SONIC TORQUE®

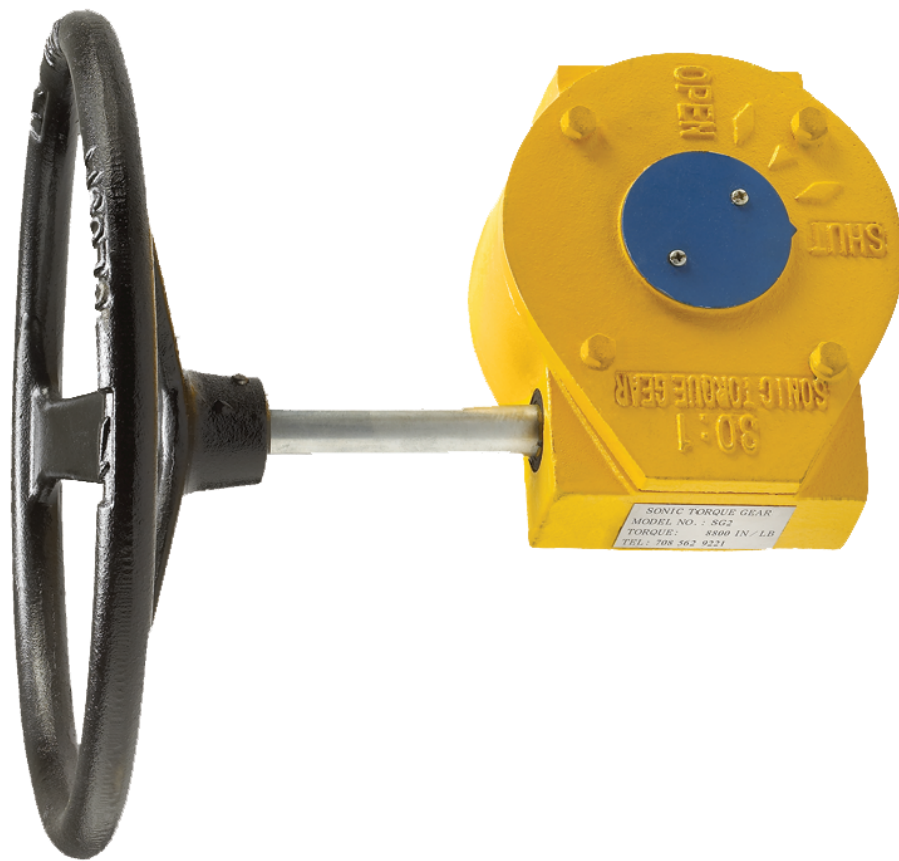

GEAR OPERATOR

SONIC TORQUE®

DIMENSIONS

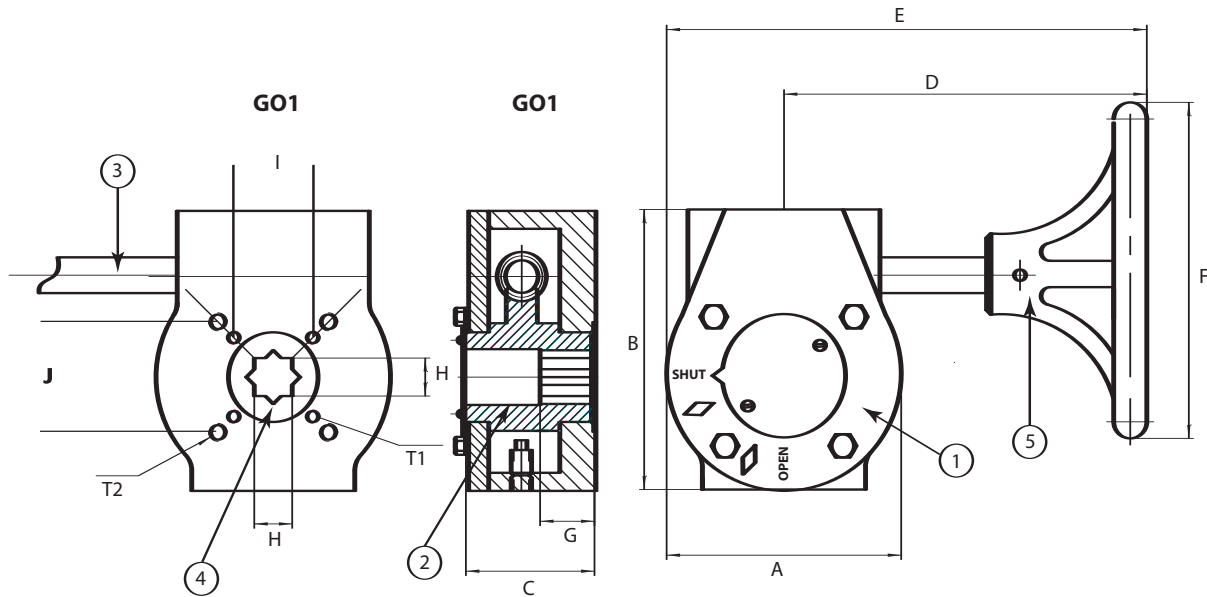

GO2-4

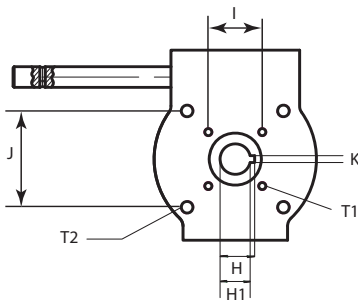

PART NO.	PART	MATERIAL
1	Body	Cast Iron
2	Gear	Steel
3	In Put Shaft	Carbon Steel
4	Drive	Ductile Iron
5	Hand Wheel	Cast Iron

	OUTPUT TORQUE (IN - LBS)	RATIO
GO1	2640	24:1
GO2	8800	30:1
G03	13200	50:1
G04	26400	80:1

	A	B	C	D	E	F	G	H	H1	I	J	K	T1	T2
GO1	4.13	4.87	2.53	6.17	7.99	6.00/10.00	1.00	0.67	X	1.96	2.75	X	M6	M8
GO2	6.02	6.90	2.97	9.60	12.28	12.00	3.07	1.26	1.10	2.76	4.92	0.32	M8	M12
G03	6.93	7.93	3.29	8.75	12.36	12.00	3.30	1.58	1.42	4.01	5.52	0.32	M10	M16
G04	10.25	11.15	4.20	11.22	15.94	15.49	4.37	2.14	1.89	4.92	6.49	0.50	M12	M20



A DIVISION OF **Sharon** DRIPPING & EQUIP., INC.

(708) 409-4150

Fax: (708) 409-4151

Email: info@sonictorque.com

www.sonictorque.com

1260 Garnet Drive

Northlake, Illinois 60164 U.S.A.